

TROUBLESHOOTING CHART:

Problem	Cause	Solution
1. No discharge	a. No water b. Magnetic valve not functioning c. Excessive water pressure d. Eductor clogged	a. Open water supply b. Install valve parts kit c. Install regulator if water pressure exceeds 85 PSI d. Clean* or replace
2. No concentrate draw	a. Clogged foot valve b. Metering tip or eductor has scale build-up c. Low water pressure d. Discharge tube and/or flooding ring not in place e. Concentrate container empty f. Inlet suction stub not screwed into eductor tightly g. Clogged water inlet strainer	a. Clean or replace b. Clean (descale)* or replace c. Minimum 25 PSI (with water running) required to operate unit properly d. Push tube firmly onto eductor discharge hose barb, or replace tube if it doesn't have a flooding ring e. Replace with full container f. Tighten, but do not overtighten g. Disconnect inlet water line and clean strainer
3. Excess concentrate draw	a. Metering tip not in place	a. Screw correct tip into stub on eductor
4. Failure of unit to turn off	a. Water valve parts dirty or defective b. Magnet doesn't fully return c. Push button stuck d. Excessive water pressure	a. Clean* or replace with valve parts kit b. Make sure magnet moves freely Replace spring if short or weak c. Realign cabinet d. Install regulator if pressure exceeds 85 PSI

* In hard water areas, scale may form inside the discharge end of the eductor, as well as in other areas of the unit that are exposed to water. This scale may be removed by soaking the eductor in a descaling solution (deliming solution). To remove an eductor located in the cabinet, firmly grasp backflow preventer and unthread eductor. Replace in same manner. This will avoid loosening the backflow preventer. Alternatively, a scaled eductor can be cleaned (or kept from scaling) by drawing the descaling solution through the unit. Operate the unit with the suction tube in the descaling solution. Operate the unit until solution is drawn consistently, then flush the unit by drawing clear water through it for a minute. Replace concentrate container and put suction tube into concentrate.



3000 Disney Street
 Cincinnati, OH 45209
 888-246-2665

90076585
 Rev. C 9/08



CIMCOOL® METALWORKING FLUID MIX STATION

Package Should Contain:

1. Proportioner unit.
2. Supply tube assembly.
3. Discharge tubes (2).

Part Number • EQ02874

(UPC 66250502874)

4. Metering tip kit.
5. Mounting anchor kit.
6. Instruction sheet with parts list/diagrams

THANK YOU FOR YOUR INTEREST IN OUR PRODUCTS

Please use this equipment carefully and observe all warnings and cautions.

NOTE

WEAR	protective clothing and eyewear when dispensing chemicals or other materials.
ALWAYS	observe safety and handling instructions of the chemical manufacturers.
ALWAYS	direct discharge away from you or other persons or into approved containers.
ALWAYS	dispense cleaners and chemicals in accordance with manufacturer's instructions. Exercise CAUTION when maintaining your equipment.
KEEP	equipment clean to maintain proper operation.
WEAR	protective clothing and eyewear when working in the vicinity of all chemicals, filling or emptying equipment or changing metering tips.
ALWAYS	re-assemble equipment according to instruction procedures. Be sure all components are firmly screwed or latched into position.
ATTACH	only to tap water outlets (85 PSI maximum).

Overview:

The CIMCOOL METALWORKING FLUID MIX STATION is designed to mix one metalworking fluid concentrate at two different mix ratios. The CHARGE mix ratio is labeled on the left side (or RED BUTTON), the MAKE UP mix ratio is labeled on the right side (or GREEN BUTTON).

Typically, metalworking fluids are charged at a mix ratio slightly richer than the make up mix ratio. For example, if the desired mix ratio for a given product is 5% (19:1), then the make up mix ratio may be 4% (24:1) to maintain the desired concentration over time (due to evaporation and carryoff). Contact CIMCOOL Technical Service (513-458-8199) to obtain the recommended mix ratio for your application as well as the correct color-coded metering tip.

The supply tube assembly is designed to siphon metalworking fluid concentrate from either a drum or pail. The MIX STATION is designed to be mounted on a wall or beam, above the concentrate drum or pail. Modifying either the supply tube assembly or the discharge hose assemblies will affect the flow rate and accuracy of the MIX STATION.

Installation and Operation:

1. Remove cabinet cover. Drill holes for the three wall anchors with a 5/16" drill bit, using the cabinet back as a template for spacing of the mounting screws. Install mounting anchors, and then screw in top two anchors. Slide key holes in cabinet back over screw heads, tighten screws, then install bottom screw. Do not mount more than 6 feet (1.8 meters) above the bottom of the concentrate container, nor below the highest concentrate level (never have concentrate supply higher than the proportioner).
2. Select a metering tip for each eductor (see next section), and thread into suction stubs on eductor bodies.
3. Supply tube assembly should reach from suction stubs on eductors to bottom of the concentrate container. Loosen worm gear clamps on the open ends of the supply tube assembly. Slip one open end of supply tube assembly through notch in left side of the cabinet and push over the suction stub/metering tip on the left eductor. Tighten worm gear clamp onto suction stub. Slip other open end of supply tube assembly through notch in right side of cabinet and push over the suction stub/metering tip on the right eductor. Tighten worm gear clamp onto suction stub.
4. Install discharge tube assembly. Do not remove flooding rings from inside the tubes. Slide ends of hoses with flooding rings over eductor discharge outlets. Hooks on opposite end of assembly are provided to allow discharge tube assembly to conveniently hang from the side cabinet openings. Hang up the discharge tube assembly after each use to prevent continuous siphoning of concentrate.
5. Place foot valve end of supply tube assembly into concentrate container. REMEMBER TO CHECK FOOT VALVE STRAINER PERIODICALLY FOR CLOGGING: CLEAN IF NECESSARY.
6. Replace cabinet cover. Push the sides in, behind the latch holes, to snap the cover in place. The two screws provided may be installed in the holes in the cabinet sides.
7. Connect water supply hose of at least 1/2" ID to water inlet swivel. (Minimum 25 PSI pressure, with water running, is required for proper operation.) Turn water supply on. Typical flow rate at 40 PSIG is 3 GPM.
8. Push button to start flow of desired water and concentrate, and hold until supply tube is primed (filled). Prime the second button in the same fashion. Then push the appropriate button whenever dispensing is desired, and release button to stop flow of solution. Push-to-latch buttons (fully depressed) are supplied for continuous dispensing without holding button. To release button, simply lift from underneath. NOTE: to use as "push to latch" buttons, bend tabs (2) underneath each button towards the button.

Metering Tip Selection:

The final concentration of the dispensed solution is related to both the size of the metering tip opening and the viscosity of the liquid being siphoned. Contact CIMCOOL Technical Service (513-458-8199) for selecting the proper metering tip to obtain the recommended metalworking fluid concentration. Please refer to Table 1 for the Tip Identification Chart. One set of color-coded metering tips is included with each unit. The clear, undrilled tip is provided to permit drilling to size not listed should you need a dilution ratio that falls between standard tip sizes.

TABLE 1 TIP IDENTIFICATION CHART		
Tip Color	Orifice Diameter	Drill Size
Gray	.128	(30)
Black	.098	(40)
Light Brown/Beige	.070	(50)
Red	.052	(55)
White	.043	(57)
Blue	.040	(60)
Medium Brown/Tan	.035	(65)
Green	.028	(70)
Orange	.025	(72)
Dark Brown	.023	(74)
Yellow	.020	(76)
Purple	.014	(79)
Pink	.010	(87)
Clear	Your Choice	(No Hole)

CIMCOOL MIX STATION Parts Diagram Cont.

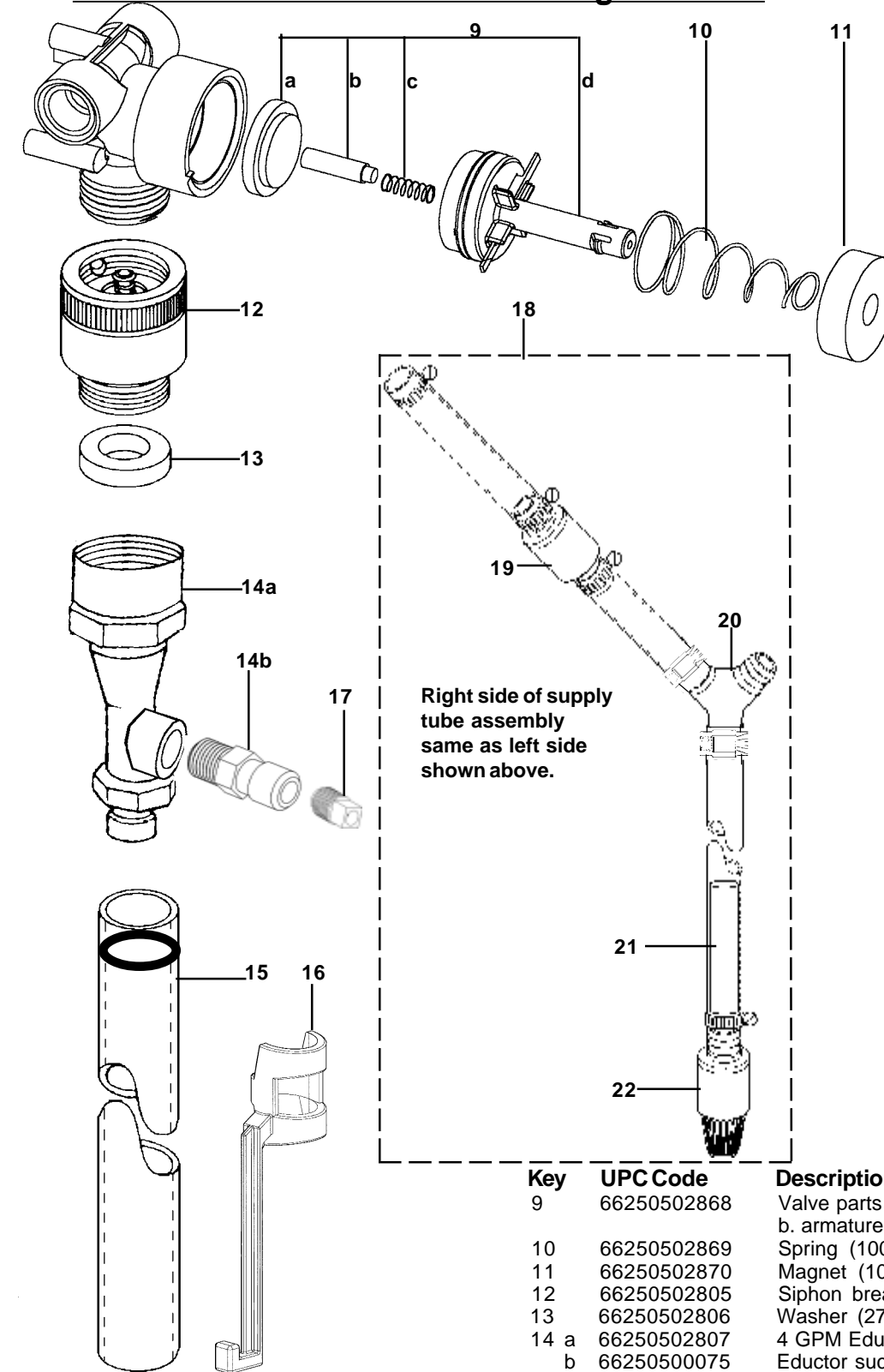

CIMCOOL MIX STATION Parts Diagram

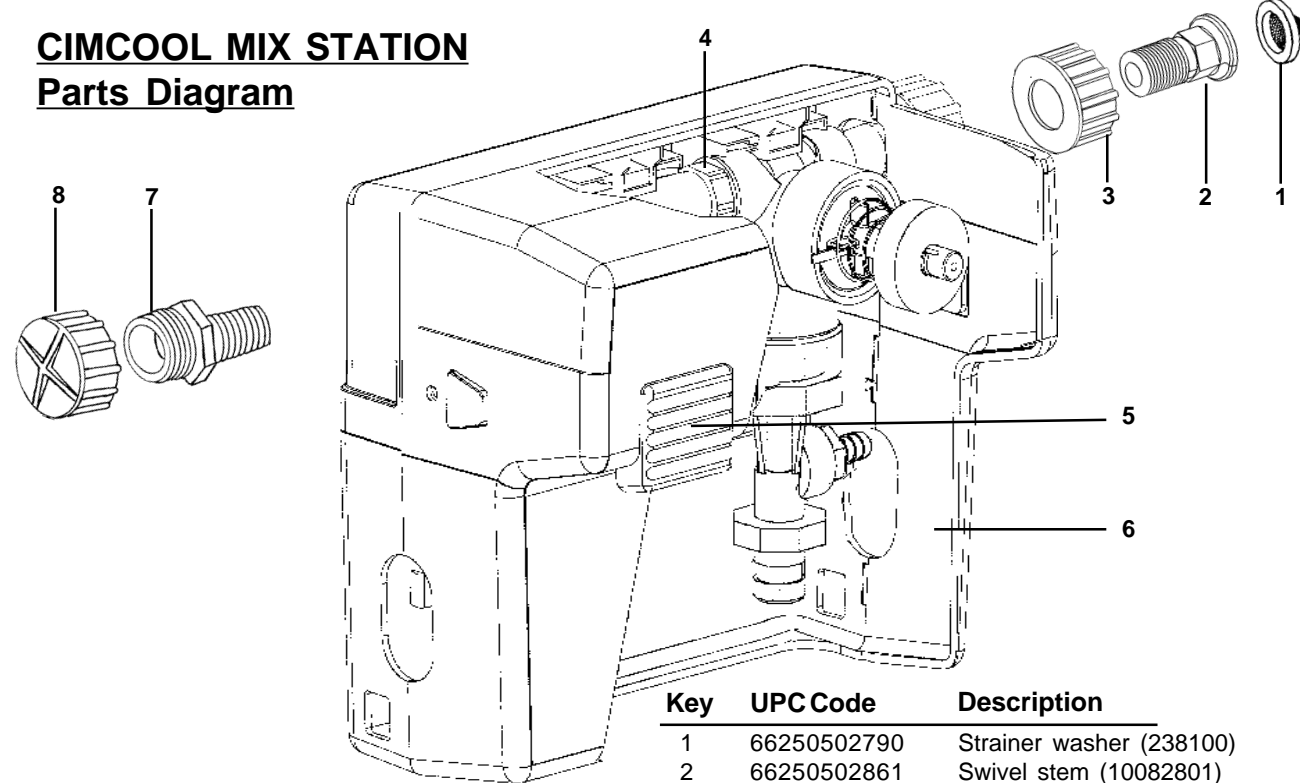

Key	UPC Code	Description
1	66250502790	Strainer washer (238100)
2	66250502861	Swivel stem (10082801)
3	66250502862	Swivel collar (10082830)
4	66250502793	Nipple (10075902)
5	66250502863	Button, green (10080713)
	66250502864	Button, red (10080712)
6	66250502865	Cabinet (10080892)
7	66250502866	Connector fitting (10082821)
8	66250502867	Connector fitting cap (10082840)

Key	UPC Code	Description
9	66250502868	Valve parts kit (10075980) a. diaphragm b. armature, c. spring, d. valve bonnet
10	66250502869	Spring (10079010)
11	66250502870	Magnet (10079000)
12	66250502805	Siphon breaker (10035310)
13	66250502806	Washer (270702)
14 a	66250502807	4 GPM Eductor (441200)
b	66250500075	Eductor suction stub (440101)
15	66250502871	Discharge tube, (4') (90048495)
16	66250502872	Hose hook, red (10080732)
	66250502873	Hose hook, green (10080733)
17	66250500144	Metering tip kit (690015)
18	66250502811	Supply tube assembly (90055410)
19	66250502812	In-line check valve (10076303)
20	66250502813	Y fitting (90055400)
21	66250502814	Weight (250006)
22	66250502815	Foot valve -- high concentrate (10076305)
NOT SHOWN:		
	66250502816	Security screws - cabinet sides (641751)